

# QUALITY ELEVATOR PRODUCTS, INC.

7760 Merrimac Avenue • Niles, Illinois • 60714  
847-581-0085 • Fax 847-581-0095 • www.qualityelev.com

## FOLLOWER GUIDE ASSEMBLY WORKSHEET AND QUOTE FORM

Name: \_\_\_\_\_ Quote/PO: \_\_\_\_\_  
 E-mail: \_\_\_\_\_ Phone: \_\_\_\_\_  
 Company: \_\_\_\_\_ Date: \_\_\_\_\_  
 Address: \_\_\_\_\_

### Follower Guide Data

Model FGA \_\_\_\_\_  
 D.B.G. \_\_\_\_\_  
 Plunger Size \_\_\_\_\_  
 Travel \_\_\_\_\_  
 Rail Size \_\_\_\_\_

**Note:**  
 Follower guides are custom made and non-returnable. Please recheck before submitting.

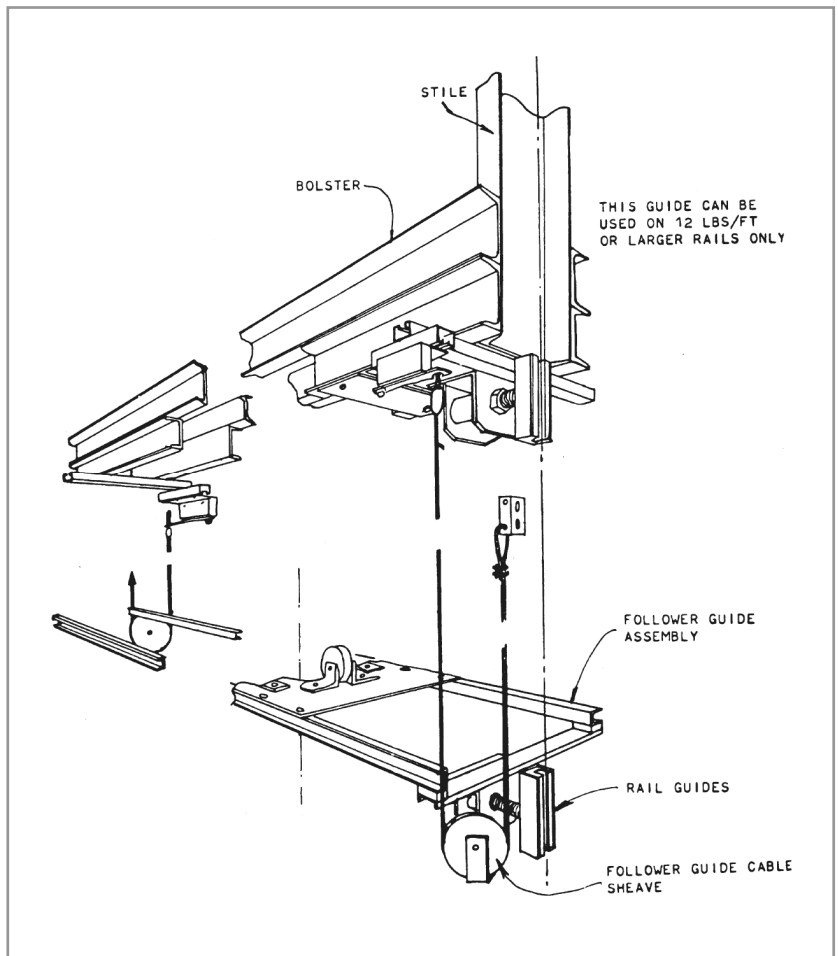

### Notes

\_\_\_\_\_  
 \_\_\_\_\_

Please fill out the form and e-mail it to [sales@qualityelev.com](mailto:sales@qualityelev.com) or fax it to 847-581-0095.