

PENDANT INSPECTION STATIONS

Temporary Inspection/Run Stations

Pendant inspection stations come with Emergency Stop red “Mushroom” switch, “ON”, “UP”, “DOWN” push button switches, and traveling pendant cable. User configurable. Yellow color, IP65 NEMA 4 high impact ABS plastic housing. Hanger ring for easy attachment to strain relief cable. CSA listed. Also available with additional 2-position Key switch and knockout holes for optional switches, buttons or indicator jewels. Two keys are included. Stations could be prewired according to customer specifications. Custom cable lengths are available.

- Ergonomic design
- High impact ABS plastic housing
- Yellow high safety color
- 16’ Traveling pendant cable
- IP65, NEMA 4 water resistant
- All switches rated UI 600VAC, Ith 10A

Pendant Inspection Stations

Model PS-824

- Includes HS-824 housing and TC10-18 cable
- “Stop” latching red “Mushroom” switch, Push-to-Stop / Turn-to-Run, SPST 1NC
- “ON” push button switch, SPST 1NO
- “UP” push button switch, SPST 1NO
- “DOWN” push button switch, SPST 1NO

Model PS-805

- Includes HS-805 housing and TC10-18 cable
- “Stop” latching red “Mushroom” switch, Push-to-Stop / Turn-to-Run, SPST 1NC
- “ON” push button switch, SPST 1NO
- “UP” push button switch, SPST 1NO
- “DOWN” push button switch, SPST 1NO
- 2-Position Key switch with two keys, key removable in any position, DPST 1NO 1NC

Pendant Station Housings

- Assembly with switches
- High impact ABS plastic
- Yellow color

Model HS-824

Dimensions: 8”L x 3.25”W x 3.25”D

Model HS-805

Dimensions: 11.25”L x 3.25”W x 3.25”D

Pendant cable

Model TC10-18

- Not connected
- Can be prewired
- Numbered wires, 10 x 18AWG
- Lengths 16’, 0.54” Dia.
- UL and CSA listed, 140°F, 300V

Raitings

- CSA listed 186663
- CE Mark approved
- IP65 water resistant



Model HS-824



Model HS-805



QUALITY
ELEVATOR PRODUCTS, INC.

Pendant_Inspection_Stations_PS-8_071321

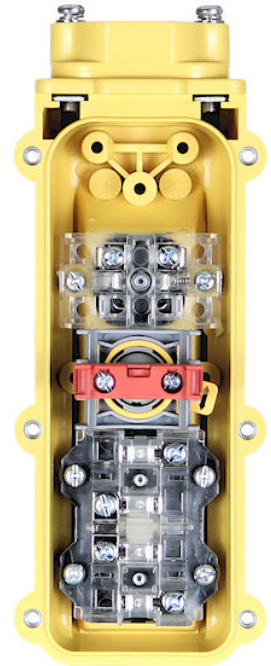
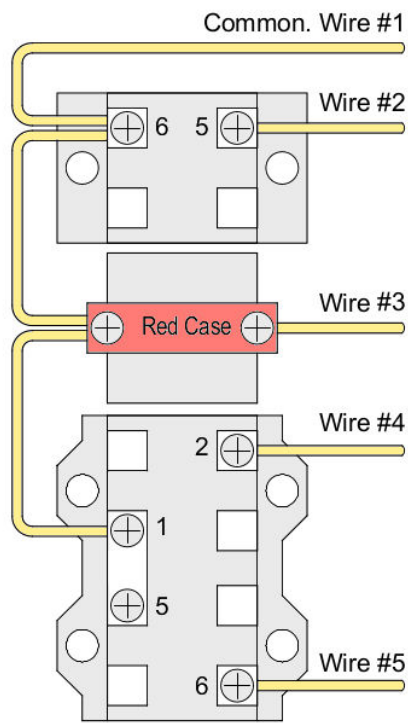
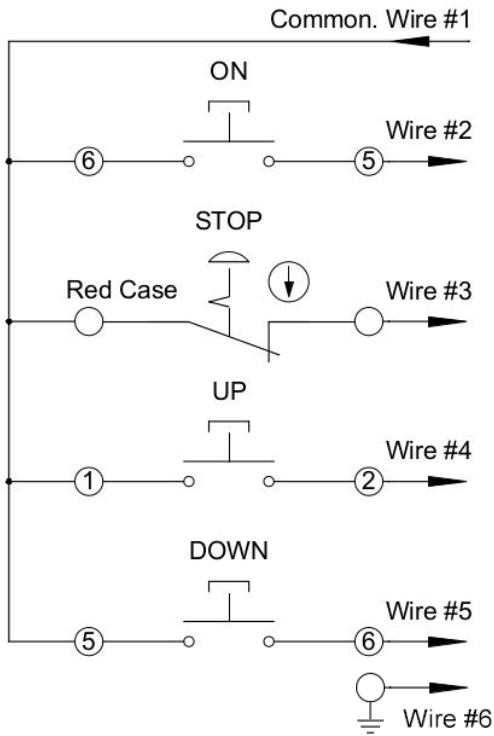

Wiring. Pendant station Model PS-824.

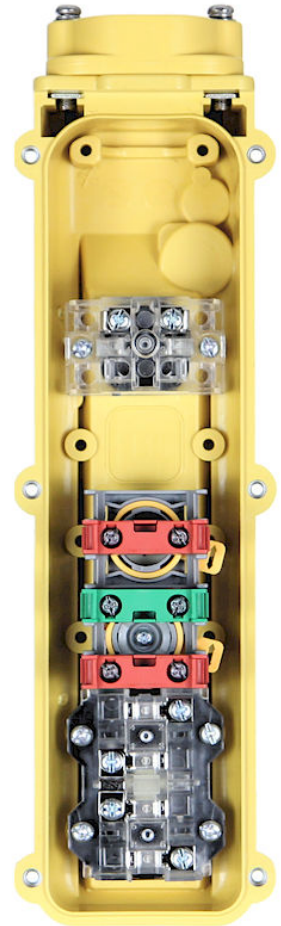
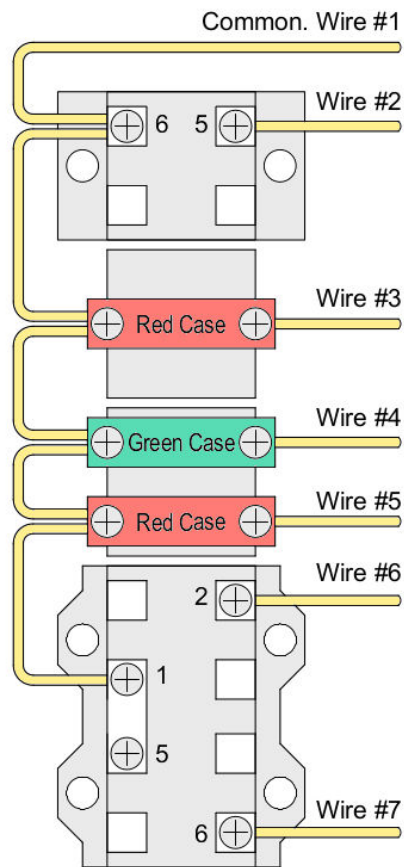
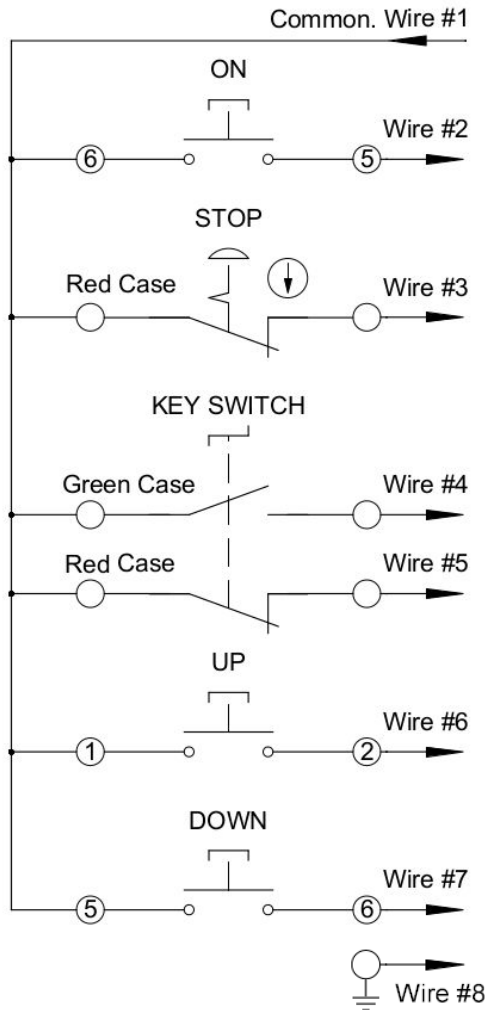

Wiring. Pendant station Model PS-805.