

# ELEVATOR AIR CONDITIONER WITH ELECTRIC HEATER

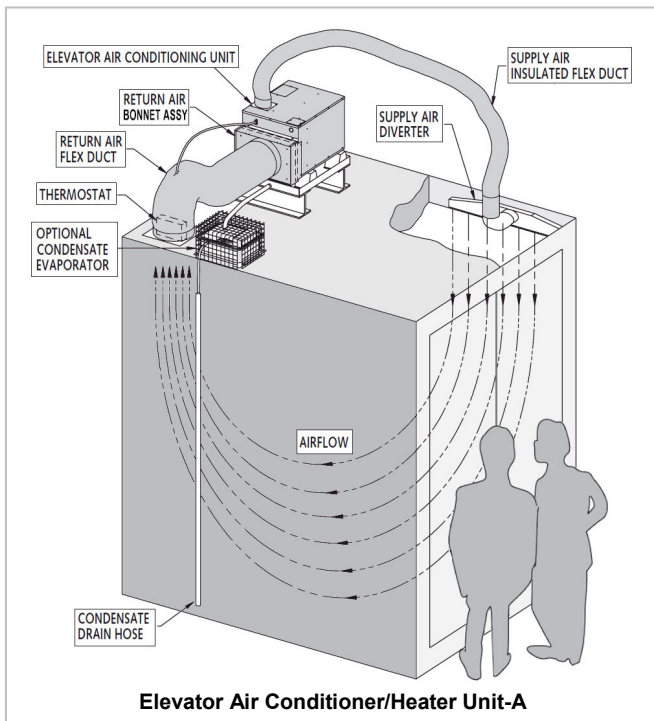

Elevator Air Conditioner/Heater Unit-A

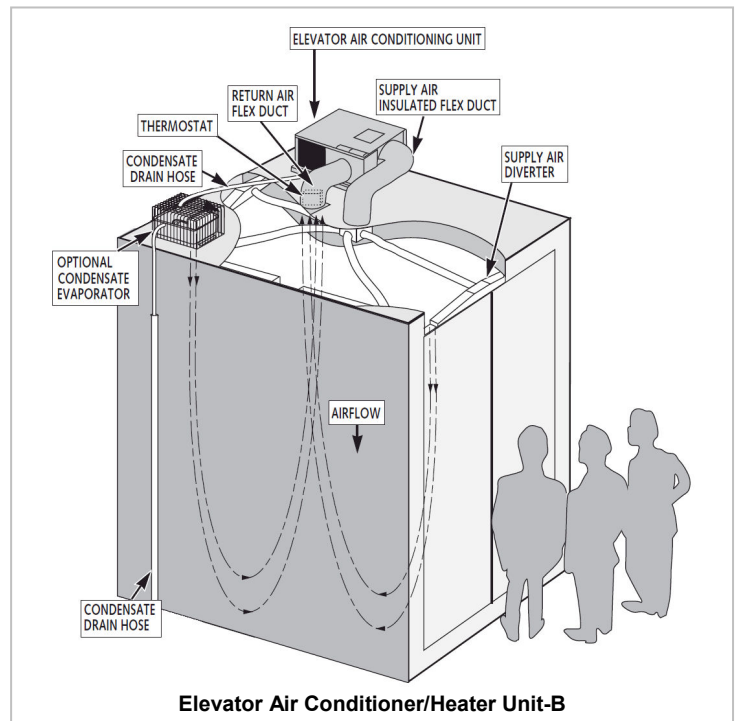

Elevator Air Conditioner/Heater Unit-B

## Elevator Air Conditioner/Heater Features

- Unit mounts on top of the elevator
- Self-contained package
- Thermostat mounted in return air duct
- 4-pin plugs, 15' armored cable for remote thermostat hookup
- Fan can be set to operate continuously
- Leak proof, factory sealed, lightweight rotary compressor
- Narrow, virtually invisible, black finish air diverters
- Shock absorbing, compressor mounts
- Noise reduction, unit mounts
- Long lasting, vibration resistance copper tubing
- Gas-flux brazed joints on the tubing to resist corrosion
- Soft start compressor circuit
- Galvanized steel construction of the outer cabinet
- Heavy-duty, corrosion-resistant, galvanized drain pan
- Evaporator freeze-up protection
- Screw type circuit board terminals simply field wiring
- Washable filter drops into return air bonnet
- High and low pressure switches to protect against fan failure or refrigerant loss. (Unit-B only)
- Normally open contact for remote monitoring of unit shutdown or power outages. (Unit-B only)

## Optional Condensate Evaporator

Includes drain pan filter to screen particles out of evaporator, overflow drain tube.

### Model AC6531-3251

Condensate evaporator recommended for Unit-A. 2,000W with a capacity of 6 pounds of water per hour. Requires separate 120VAC 20A circuit, 14"L x 12"W x 8"H, weight 15Lb.

### Model AC6533-3251

Condensate evaporator recommended for Unit-B. 3,000W with a capacity of 9 pounds of water per hour. Requires separate 120VAC 20A circuit, 21"L x 13"W x 7"H, weight 20Lb.

## Optional Thermostat

Model AC6531-3241 Auto/Manual changeover, Heat/Cool, On/Off thermostat, 7-day programmable operation.

## Elevator Air Conditioner/Heater complete set

### Unit-A: Model AC6531B692A

Primarily used on elevator cabs that open onto air-conditioned space or lobbies and small cabs that cannot accommodate bigger Unit-B. Cool/Heat 7,100/5,600BTUH, short bonnet.

### Unit-B: Model AC6533392A

Designed for large cabs or installations with glass cabs and/or glass hoistways or cabs that open onto unconditioned space or lobbies. Cool/Heat 14,000/5,600BTUH.

Elevator AC/Heater Specifications	Unit-A	Unit-B
Electrical Rating	115VAC, 60Hz, 1 Phase	
Cooling Capacity BTUH	7,100	14,000
Heating Capacity BTUH	5,600	5,600
Air Delivery CFM	150	450
Locked Rotor Cooling Amps.*	34	67
Approximate Cooling Full-Load Amps.*	9.8	16.1
Approximate Heating Full-Load Amps.*	15.4	15.7
Running Watts Cooling **	990	1,537
Running Watts Cooling ***	1,150	1,909
Running Watts Heating	1,600	1,600
Length	22-1/8"	39"
Width	18-1/8"	23"
Height	19-1/8"	18-1/8"
Weight	75 Lb	180 Lb

## Tested under the following conditions:

\* Air conditioner only. Does not include condensate evaporator.

\*\* Cooling A.R.I. Standard Conditions 80°F. DB/67°F. WB Indoor, 95°F. DB Outdoor at 115VAC.

\*\*\* Cooling A.R.I. Standard Conditions 95°F. DB/71°F. WB Indoor, 115°F. DB Outdoor at 103.5VAC.

**QUALITY  
ELEVATOR PRODUCTS, INC.**

# ELEVATOR AIR CONDITIONER WITH ELECTRIC HEATER

**Unit-A: Model AC6531B692A**

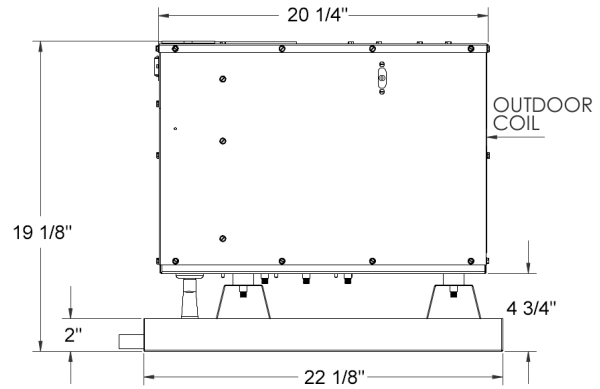
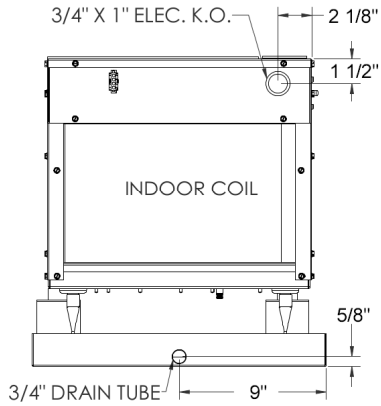
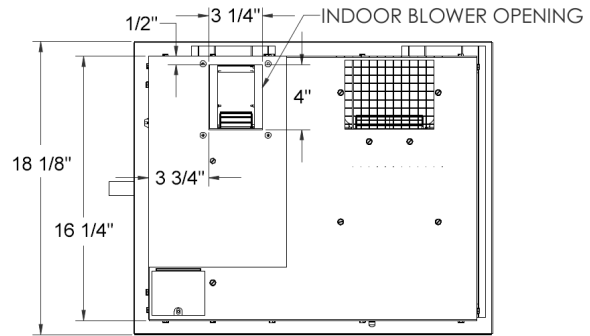
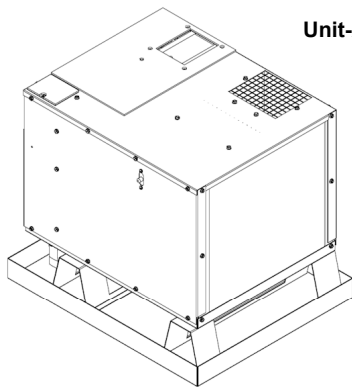

**Unit-B: Model AC6533392A**

