

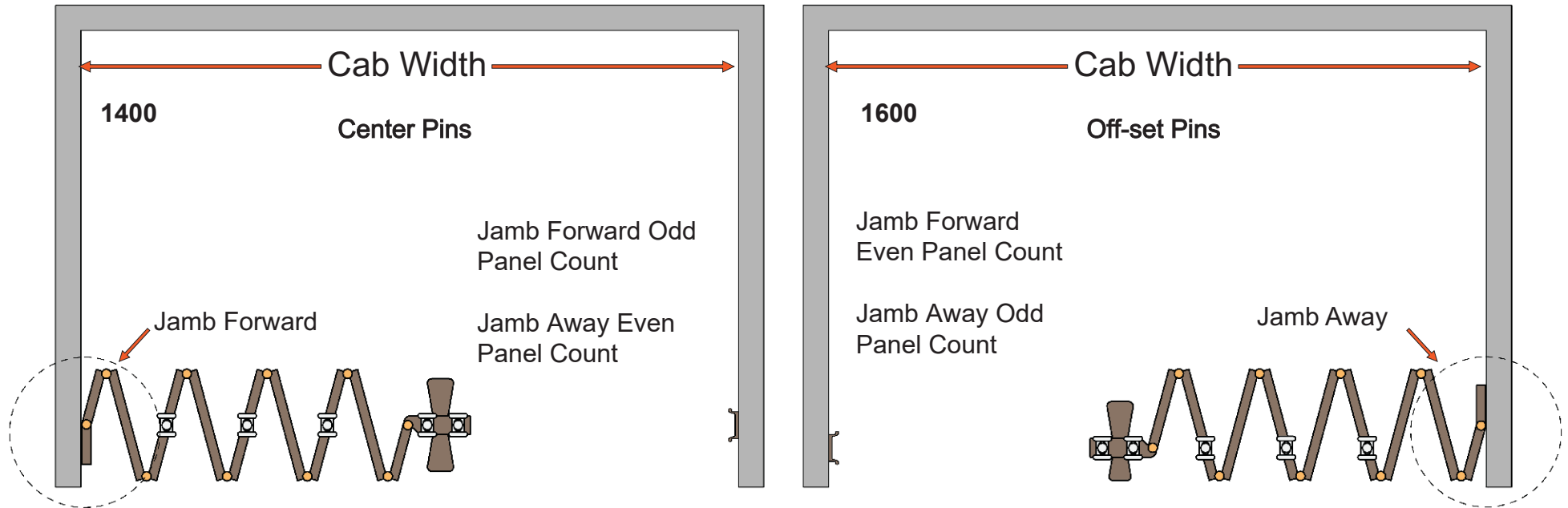

# Woodfold 1400&1600 Accordion Door Measurement Guide

The width of the door is the same as the Cab Width  
if there is a pocket increase the door width to  
include pocket depth



**HANDING IS DETERMINED STANDING ON THE OUTSIDE OF THE CAB**

*Keep in mind:*

- ⇒ Left Hand Stack or Right Hand Stack?
- ⇒ Jamb Forward or Jamb Away?
- ⇒ Center Pins or Offset Pins?

AccDoor-ElevatorGateMeasurementGuide.pdf & .cdr



Woodfold Manufacturing, Inc.  
Phone: 503.357.7181  
Fax: 503.357.7185  
woodfold.com/accordion



Made in  
Forest Grove,  
Oregon, USA

An Employee  
Owned Company



# Woodfold 1400/1600 Accordion Door Measurement Guide

The height of the door is commonly measured one of these ways:  
ALWAYS PROVIDE THE CAB HEIGHT NOT THE DOOR HEIGHT - DOORS ARE MADE TO FIT INTO THE CAB

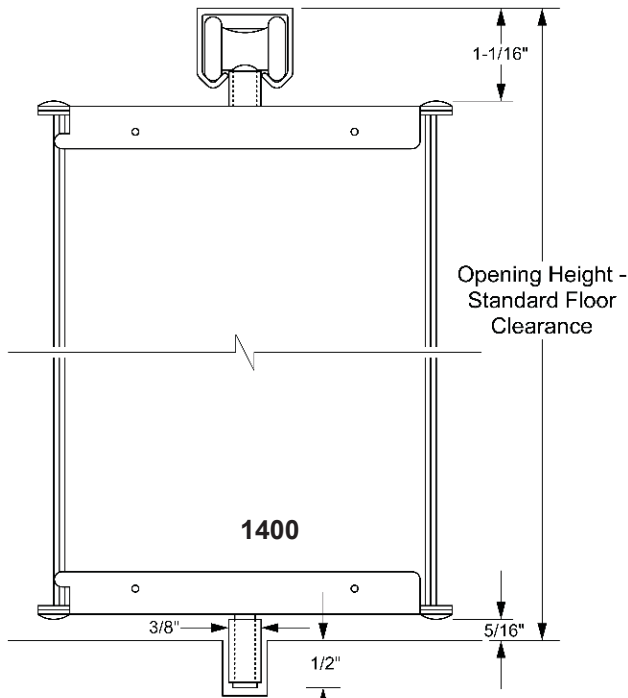

Opening Height with Standard Floor Clearance

*Floor slot dimensions by others*

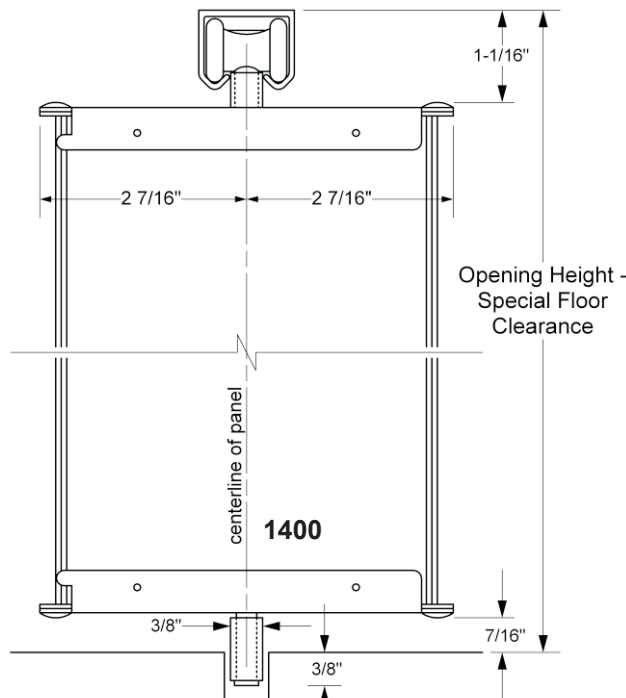

Opening Height with Special Floor Clearance

*Floor slot dimensions by others*

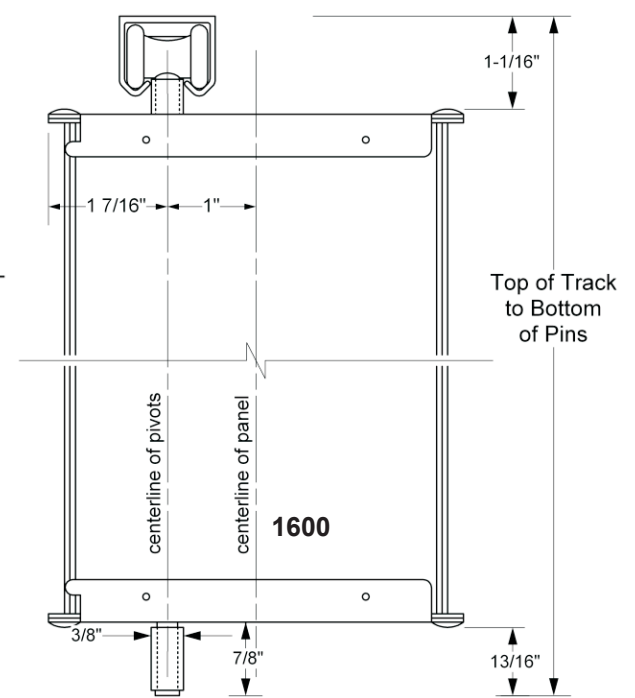

Top of Track to Bottom of Pins  
*(Offset Wheel Shown)*

*Floor slot dimensions and floor clearance by others*

Wheels and Pins are not adjustable

AccDoor-ElevatorGateMeasurementGuide.pdf & .cdr



Woodfold Manufacturing, Inc.  
Phone: 503.357.7181  
Fax: 503.357.7185  
woodfold.com/accordion



Made in Forest Grove, Oregon, USA

An Employee Owned Company

